

Design of the Gas System for the Radial Time Projection Chamber

George Jacobs, Mary Ann Antonioli, Peter Bonneau, Pablo Campero, Brian Eng, Amanda Hoebel, Mindy Leffel, Tyler Lemon, Marc McMullen, and Amrit Yegneswaran
 Physics Division, Thomas Jefferson National Accelerator Facility, Newport News, VA 23606

September 5, 2018

This note presents the design of the gas system for the Radial Time Projection Chamber (RTPC), the Drift Monitoring System (DMS) and for the buffer volume between the target and RTPC.

The gas system will provide pre-mixed 20%:80% CO₂:He for the RTPC and the DMS, and helium for the buffer volume.

After reducing the pressures of the premixed CO₂:He and that of helium down to 30 psig, the gases will be piped via 250-ft, stainless steel gas lines (outer diameter of 0.25" and inner diameter of 0.152") to the DMS, the RTPC, and the buffer volume, Fig.1. Flow limiting orifices and relief valves will protect the gas system.

Nominal flow rate through DMS and RTPC volumes, 1400 cc and 7000 cc, respectively, is expected to be ~120 sccm, which will be measured by a MKS mass flow controller with a range of 6–260 sccm.

RTPC pressure is anticipated to be 760.2 Torr, 0.2 Torr above atmospheric pressure (~760 Torr). A differential pressure transducer with a range of ±10 Torr will monitor the differential pressure between the DMS and RTPC volumes, which is expected to be 0–0.1 Torr.

The expected pressure in the buffer volume is 760.2 Torr. Absolute pressure in the buffer volume will be measured with an absolute pressure transducer with a range of 0–1000 Torr. A flow meter with valve will measure the helium flow (Fig.1), which is expected to be 10–20 sccm.

Gases will be vented to the atmosphere via mineral oil bubblers, which have 0.1 inches of mineral oil above bottom of tube (~0.2 Torr). The bubblers act as check valves to prevent backflow of air into the system, maintain detector pressure and provide visual indication of gas flow.

The valve panel, Fig. 2, is the operations center of the gas system. For instance, to remove DMS, the bypass valve MV4 must be opened first, then inlet valve MV3 must be closed,

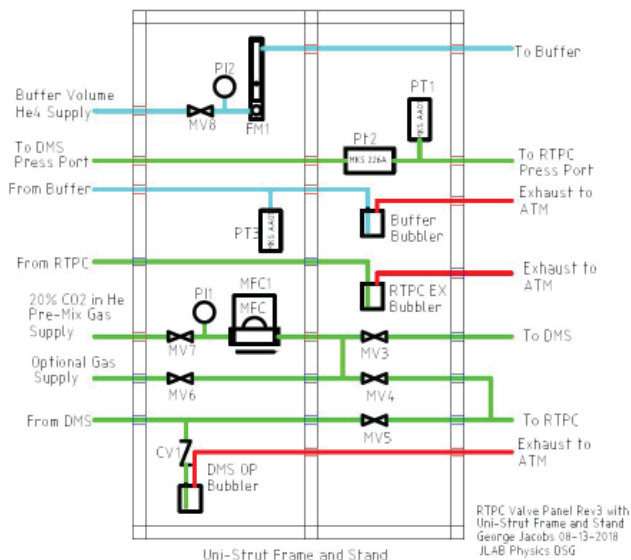

FIG. 2. RTPC valve panel diagram.

and lastly gas outlet valve MV5 must be closed.

In case the valve sequence is engaged incorrectly, e.g. MV3 open, MV4 closed, and MV5 closed, gas pressure in DMS would increase, eventually damaging the module; this possibility is prevented by the overpressure protection check valve CV1, which limits the pressure in the DMS to 52 Torr.

A GUI running on National Instruments cRIO will be used to control the MFC and read back the flow and pressure signals; these signals will be transmitted to EPICS.

To conclude, the gas system design has been approved.

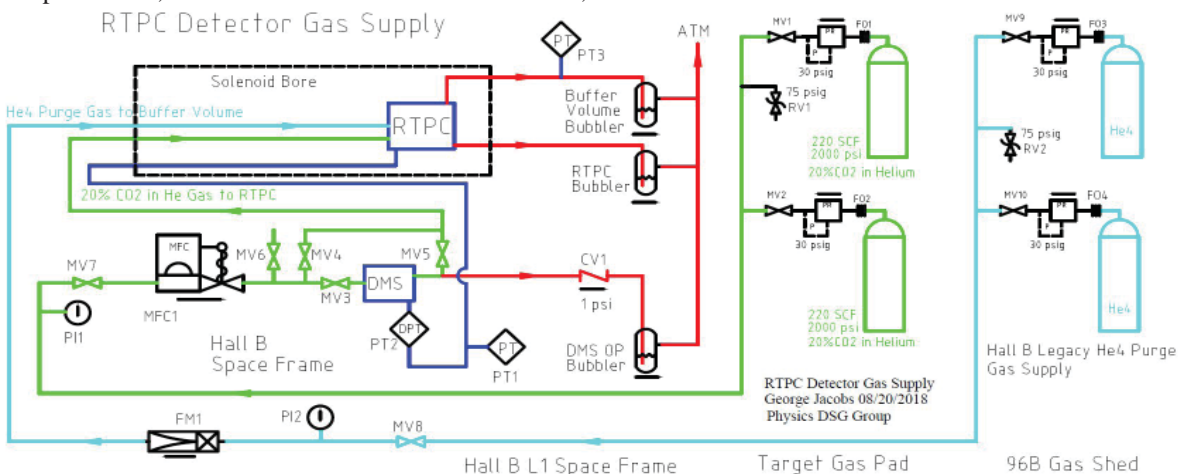

FIG. 1. Diagram for the RTPC gas supply system.